

作成承認印

配布許可印



AF-I Nikkor ED 400mm f/2.8 D IF

REPAIR MANUAL

修 理 指 針

Nikon | NIKON CORPORATION
Tokyo, Japan



© Copyright 1994
ALL RIGHTS RESERVED
無断転載を禁ず!!

目 次

組立図	-----	F 1
実体配線図	-----	F 5
回路図	-----	F 6
メインFPC	-----	F 7
LED FPC	-----	F 8
ICピン配置表	-----	F 9
仕様	-----	M 1
分解・組立・調整	-----	L 1

CONTENTS

Construction of the Lens	-----	F 1
Wiring Diagram	-----	F 5
Circuit Diagram	-----	F 6
Main FPC	-----	F 7
LED FPC	-----	F 8
IC TERMINALS	-----	F 9
Specifications	-----	M 1
Disassembling/Assembling/Adjustments	---	L 1

作成承認印	配布許可印
	

AF-I Nikkor ED 400mm f/2.8 D IF

PARTS LIST

修理部品表

Nikon | NIKON CORPORATION
Tokyo, Japan

© Copyright 1994
ALL RIGHTS RESERVED
無断転載を禁ず //

目 次

部品表編

記号説明	-----	K 1
テープ類TA設定部品一覧表	-----	K 3
リードワイヤー一覧表	-----	K 4
収縮チューブ一覧表	-----	K 5
展開図の見方	-----	K 6
展開図中の部品位置を確認する手順	-----	K 7
(1) 展開図	-----	P 1
(2) 部品表	-----	P 4

C O N T E N T S

PARTS LIST

MARKS IN THE PARTS LIST	-----	K 1
TAPE AND FILMS WITH PREFIX ALPHABETS TA	-----	K 3
LEAD WIRE LIST	-----	K 4
THERMAL CONSTRUCTION TUBE LIST	-----	K 5
HOW TO USE EXPLOSION DRAWINGS	-----	K 6
HOW TO FIND THE PATR WITH NUMBER IN THE DRAWING	-----	K 7
(1) Exploded Drawings	-----	P 1
(2) Parts List	-----	P 4

記号説明 MARKS IN THE PARTS LIST

(1) 機械標準品

下の表に示す機械標準品の部品番号は品名、種類、呼び径、長さを示しています。

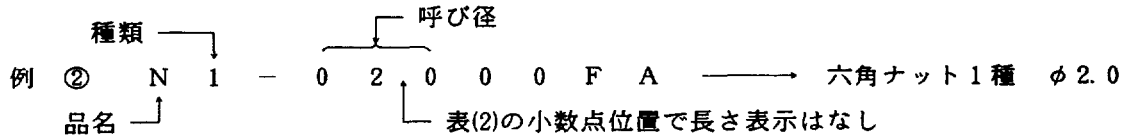
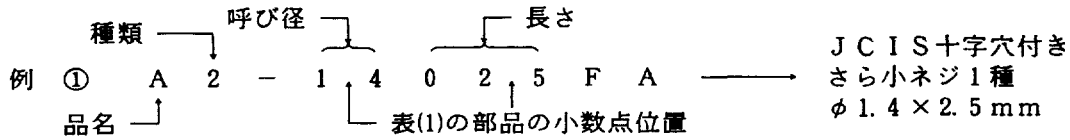

(1) Standard mechanical parts Reference Number in the Parts List

A. Screw · Pin

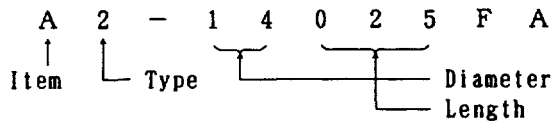

B. Nut · Washer · Snap ring



表 1

品名 Item	種類 Type	品名 Item	種類 Type
J C I S 十字穴付き小ねじ 1 種 Cross-point screw 1	A	なべ Pan	1
		さら Countersunk	2
		丸さら Oval	3
J C I S 十字穴付き小ねじ 3 種 Cross-point screw 3	B	なべ Pan	1
		さら Countersunk	2
		丸さら Oval	3
十字穴付き小ねじ Cross-point screw	C	なべ Pan	1
		さら Countersunk	2
		丸さら Oval	3
		トラス Trus	4
十字穴付きタップタイ タイトねじ B 型 Cross-point tapped screw B	F	なべ Pan	1
		さら Countersunk	2
十字穴付きタップタイ タイトねじ B 型 1 種 Cross-point tapped screw B1	G	なべ Pan	1
		さら Countersunk	2
		丸さら Oval	3
十字穴付きタップタイ タイトねじ B 型 3 種 Cross-point tapped screw B3	H	なべ Pan	1
		さら Countersunk	2
		丸さら Oval	3
表 2			
		品名 Item	種類 Type
	N	六角ナット Hexagon nut	1 種 Type 1 1 3 種 Type 3 3
		R	平座金 Washer
S	ばね座金 Spring washer		5
			E 型止め環 E-snap ring

(2) 販売区分欄 The term of sale colum

記号 Mark	説明	Explanation
○	Can be Supplied individually	単独部品として販売するもの
△	Not supplied individually but only as subassembly.	部組品でなければ販売しないもの
○△	Supplied either as part or subassembly	単独部品でも部組品でも販売するもの
×	Not considered as repair part	修理部品と考えないもの
※	Should be sent to the factory if the repair needed.	単体では交換できないので、組む場合に工場での加工が必要なもの
☒	Delivered as a product from the sales department (i. e., not supplied as repair part)	商品として販売店で販売しているもの (修理部品扱いはしない)

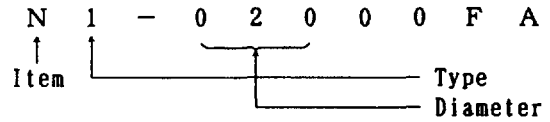
(3) 備考欄 The remarks colum

F-601M	Part number used in common	共通部品番号
(Blue × 125mm)	Lead wire (color × length)	コードの色と長さ
53F-2013 (FM-780028)	Technical information ref. number (number in parenthesis; English edition)	製品技術資料No ()内は英文
(2.1×3.8 × 0.07)	Washer (internal diameter × external diameter × thickness)	ワッシャー (内径×外径×厚さ)
(Black)	Black-finished parts	黒部品
(d=0.2)	Diameter of wire	線型=0.2
(t= 1)	Thickness	厚さ=1
Rev.	Revision	訂正
Add.	Addition	追加
Dis.	Discontinuation	廃止
OLD	Parts of the intial design	旧部品
◆	Limited part	R P 限定出庫部品
RP-9001	Repair part information No.	R P 情報No.
R1... D1... W1... C1... Q1... P1...	Abbreviation for electronic part	電気部品記号
TA-0003	Number (TA-****) are order numbers of adhesive tape. (For the order of adhesive tape, the number 1K***-*** is not use).	接着テープ要求部番 (1K***-*** では部品要求できません。)
W-0056BE	Number (W-0056BE) are order numbers of Lead wire. (For the order of Lead wire, the number 1K***-*** is not use).	リードワイヤ要求部番 (1S***-*** では部品要求できません。)

* VERSATILE PART

* 既出部品

Apart maked with this pentagonal symblo is used commonly in the arcitecture of other products. That is called "VERSATILE PART". Note that every part, bearing new part number of eleven places, will turn into a VERSATILE PART when it is used in the design of future product.

テープ類TA設定部品一覧表

TAPES AND FILMS WITH PREFIX ALPHABETS TA Dec. 17, 1991

部品 No. Part No.	名称 Name of part	色 Color	厚さ Thickness (t=mm)	幅 Widths (mm)	長さ Length (m)	要求単位 Q'ty for a unit for ordering
TA-0001	ポリエステルフィルム Tape	透明 Transparent	0.025	10	30	1巻 1 roll
TA-0002	ポリエステルフィルム Tape	透明 Transparent	0.025	20	30	1巻 1 roll
TA-0003	両面接着テープ Both sided adhesive tape	白 White	0.16	10	2	1巻 1 roll
TA-0004	両面接着テープ Both sided adhesive tape	黒 Black	0.14	12	50	1巻 1 roll
TA-0005	ポリエステルフィルム Tape	黄 Yellow	0.06	19	66	1巻 1 roll
TA-0006S	アセテートクロス (シート) Tape (200x120/sheet)	黒 Black	0.23	6	200 (mm)	1set (20pcs)
TA-0007	銅箔導電性 Tape, copper foil	銅箔 Copper foil	0.11	4	6	1巻 1 roll
TA-0008	ポリエステルフィルム Tape	透明 Transparent	0.055	30	30	1巻 1 roll
TA-0009	カプトンフィルム Tape	琥珀 Amber	0.07	6	30	1巻 1 roll
TA-0010	両面接着テープ Both sided adhesive tape	乳白色 Opal	0.16	15	36	1巻 1 roll
TA-0011	ポリエステルフィルム Tape	黒 Black	0.06	10	30	1巻 1 roll
TA-0012	ポリエステルフィルム Tape	透明 Transparent	0.025	6	30	1巻 1 roll
TA-0013	アセテートクロス (シート) Tape (200x120/sheet)	黒 Black	0.23	20	200 (mm)	1set (20pcs)

リードワイヤ—覽表

LEAD WIRE LIST

DEC. 17, 1991

部 品 No. Part No.	色 Color	外 形 Diameter (outer tube)	導 体 大 小 Pcs. / Diameter (lead wire)	部 品 No. Part No.	色 Color	外 形 Diameter (outer tube)	導 体 大 小 Pcs. / Diameter (lead wire)
W-0045BN	Brown	0.45mm	7×0.05mm	W-0108BK	Black	1.08mm	7×0.16mm
W-0045RE	Red	-ditto-	-ditto-	W-0108BN	Brown	-ditto-	-ditto-
W-0045OR	Orange	-ditto-	-ditto-	W-0108RE	Red	-ditto-	-ditto-
W-0045GN	Green	-ditto-	-ditto-	W-0108OR	Orange	-ditto-	-ditto-
W-0045BE	Blue	-ditto-	-ditto-	W-0108YE	Yellow	-ditto-	-ditto-
W-0045PU	Purple	-ditto-	-ditto-	W-0108GN	Green	-ditto-	-ditto-
				W-0108BE	Blue	-ditto-	-ditto-
W-0056BK	Black	0.56mm	7×0.08mm	W-0108PU	Purple	-ditto-	-ditto-
W-0056BN	Brown	-ditto-	-ditto-	W-0108GY	Gray	-ditto-	-ditto-
W-0056RE	Red	-ditto-	-ditto-	W-0108WH	White	-ditto-	-ditto-
W-0056OR	Orange	-ditto-	-ditto-				
W-0056YE	Yellow	-ditto-	-ditto-	W-0120BK	Black	1.2 mm	7×0.18mm
W-0056GN	Green	-ditto-	-ditto-	W-0120BN	Brown	-ditto-	-ditto-
W-0056BE	Blue	-ditto-	-ditto-	W-0120RE	Red	-ditto-	-ditto-
W-0056PU	Purple	-ditto-	-ditto-	W-0120OR	Orange	-ditto-	-ditto-
W-0056GY	Gray	-ditto-	-ditto-	W-0120YE	Yellow	-ditto-	-ditto-
W-0056WH	White	-ditto-	-ditto-	W-0120GN	Green	-ditto-	-ditto-
W-0056PK	Pink	-ditto-	-ditto-	W-0120BE	Blue	-ditto-	-ditto-
				W-0120PU	Purple	-ditto-	-ditto-
				W-0120GY	Gray	-ditto-	-ditto-
				W-0120WH	White	-ditto-	-ditto-
W-0080BK	Black	0.80mm	7×0.12mm				
W-0080BN	Brown	-ditto-	-ditto-	W-0150BK	Black	1.5 mm	40×0.08mm
W-0080RE	Red	-ditto-	-ditto-	W-0150BN	Brown	-ditto-	-ditto-
W-0080OR	Orange	-ditto-	-ditto-	W-0150RE	Red	-ditto-	-ditto-
W-0080YE	Yellow	-ditto-	-ditto-	W-0150OR	Orange	-ditto-	-ditto-
W-0080GN	Green	-ditto-	-ditto-	W-0150YE	Yellow	-ditto-	-ditto-
W-0080BE	Blue	-ditto-	-ditto-	W-0150GN	Green	-ditto-	-ditto-
W-0080PU	Purple	-ditto-	-ditto-	W-0150BE	Blue	-ditto-	-ditto-
W-0080GY	Gray	-ditto-	-ditto-	W-0150PU	Purple	-ditto-	-ditto-
W-0080WH	White	-ditto-	-ditto-	W-0150GY	Gray	-ditto-	-ditto-
W-0080LB	Light blue	-ditto-	-ditto-	W-0150WH	White	-ditto-	-ditto-
1 roll=20m							

収縮チューブ一覧表

Thermal construction tube list

Dec. 17, 1991

部品 No. Part No.	名称 Name of part	直径 Diameter (ϕ)	長さ Length (m)	備考 Remarks
TU-0001	収縮チューブ Thermal construction tube	1.0 mm	1	RP-8925
TU-0002	収縮チューブ Thermal construction tube	2.0 mm	1	RP-8925
TU-0003	収縮チューブ Thermal construction tube	3.0 mm	1	RP-8925
TU-0004	収縮チューブ Thermal construction tube	4.0 mm	1	RP-8925

展開図の見方 How to use explosion drawings

部組品 No.
Assembly No. (component parts shown
inside the broken line)

部品要求単位
Quantity per order

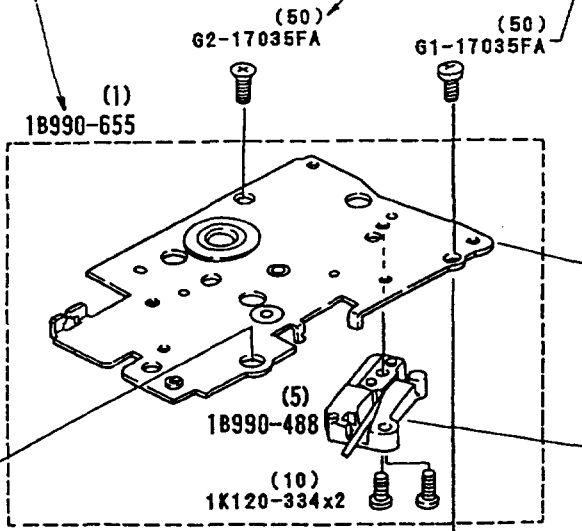

部品番号
Part No.

項目 Part Classification	販売区分 Term of Supply	記号 Mark
破線外で部番の入っているもの Part with Part No., shown outside the broken line	単部品で要求できるもの Available as individual part	○
破線外で部番のないもの Part without Part No., shown outside the broken line	修理部品と考えないもの Not available as repair part	×
破線内で部番のないもの Part without Part No., shown inside the broken line.	部組品でなければ要求できないもの Available only as assembly.	△
破線内で部番の入っているもの Part with Part No., shown inside the broken line	単部品でも部組品でも要求できるもの Available as assembly or individually	○△

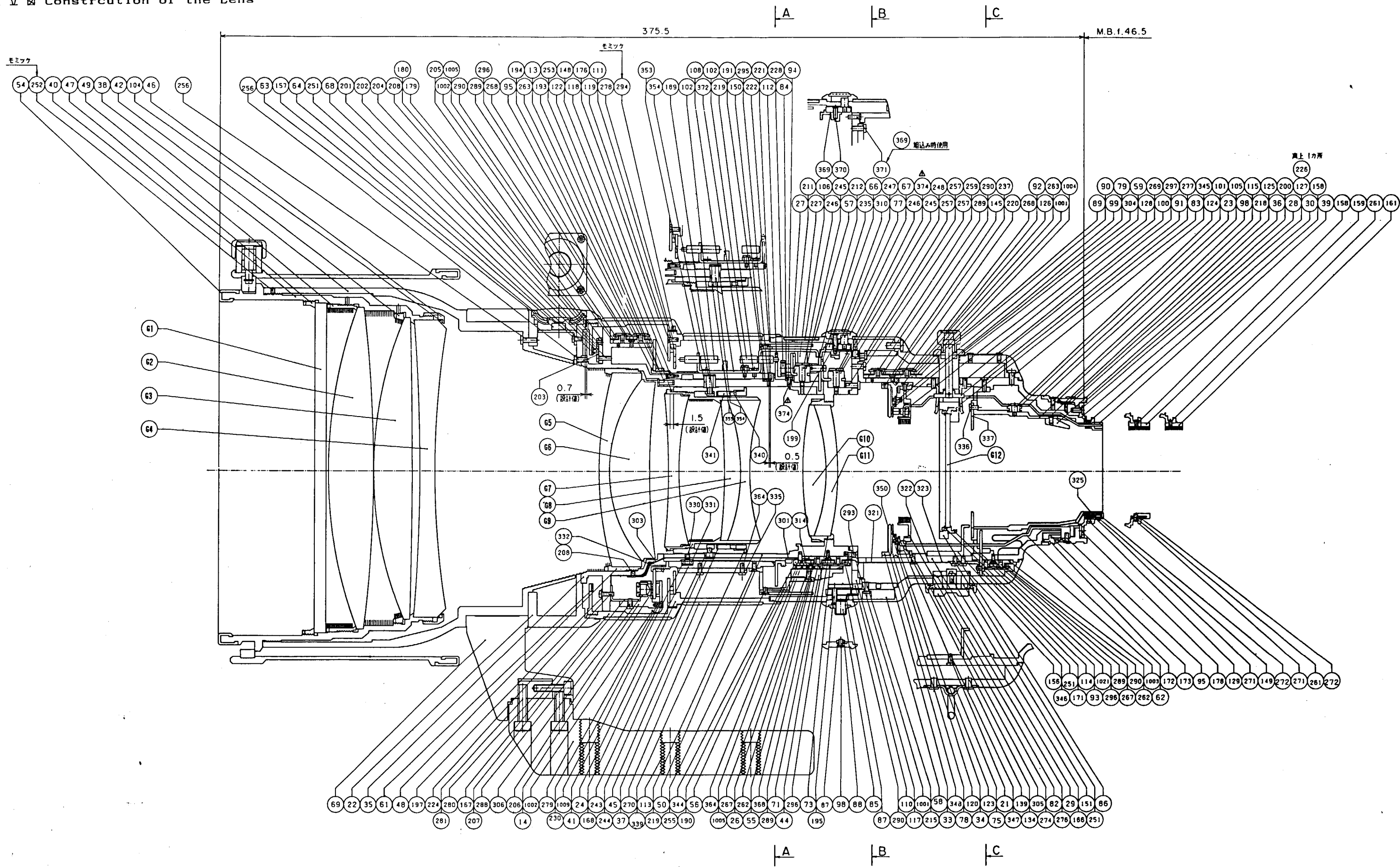

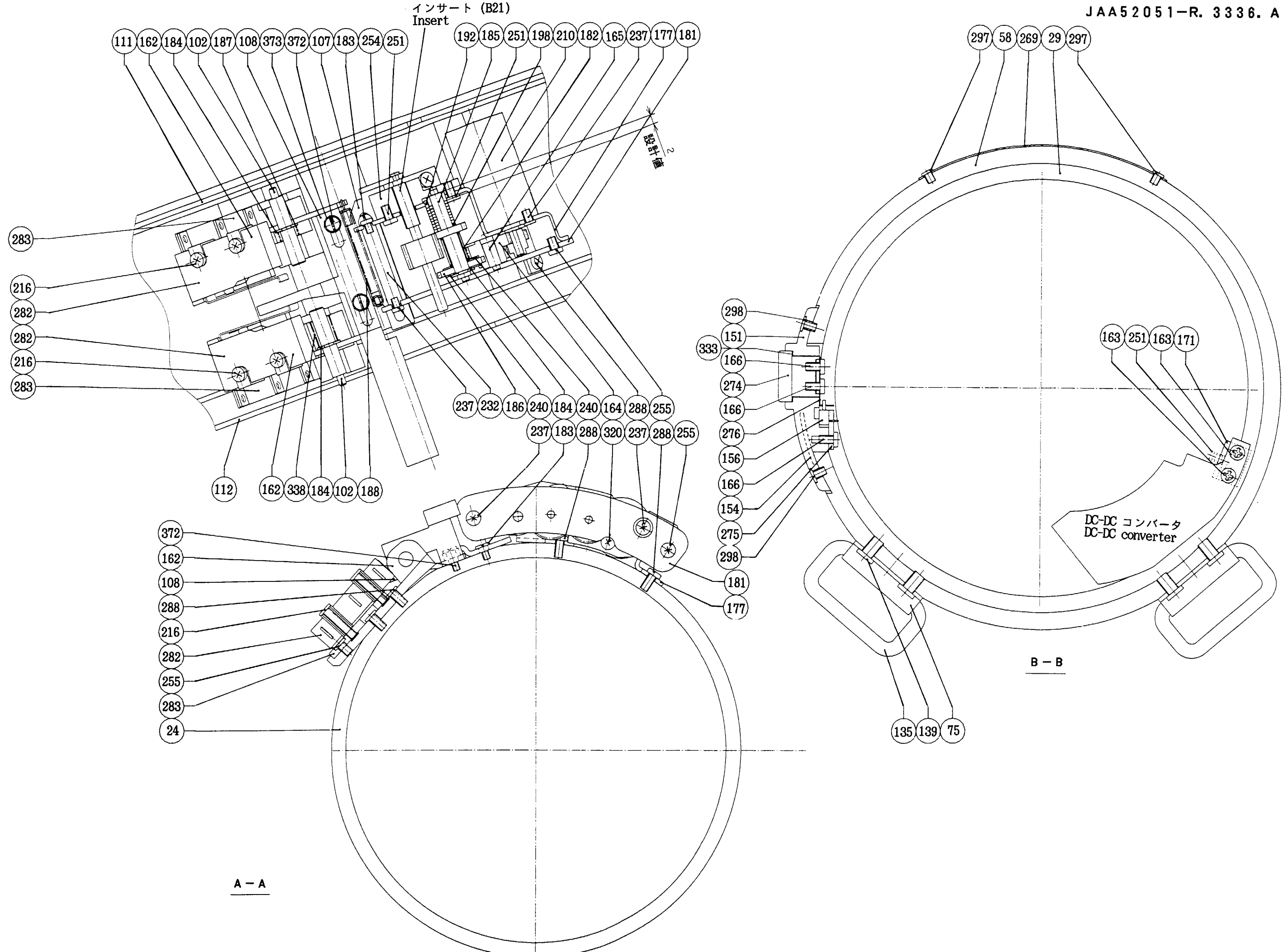

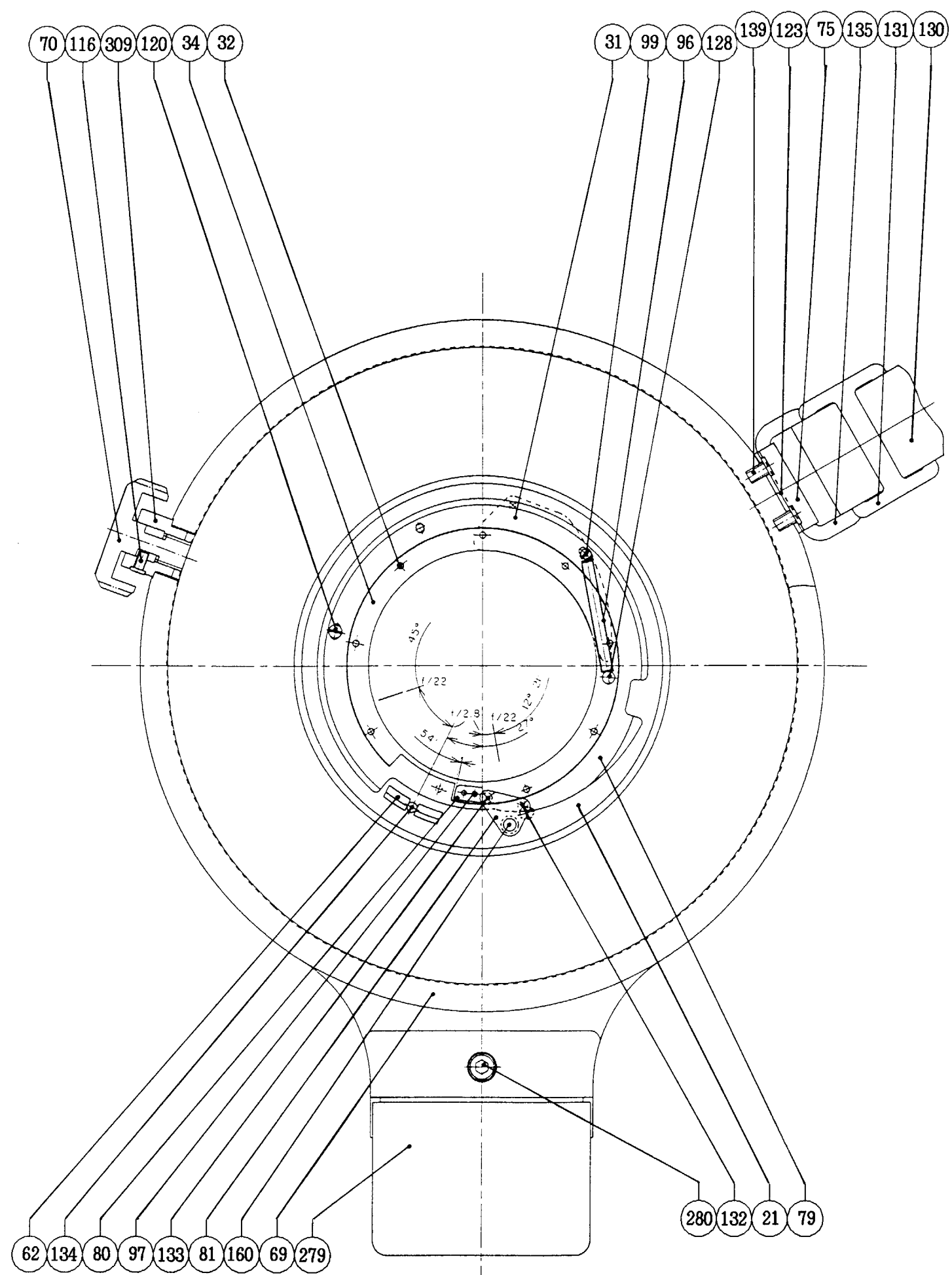

絞り部及び三脚座部 (後方より)

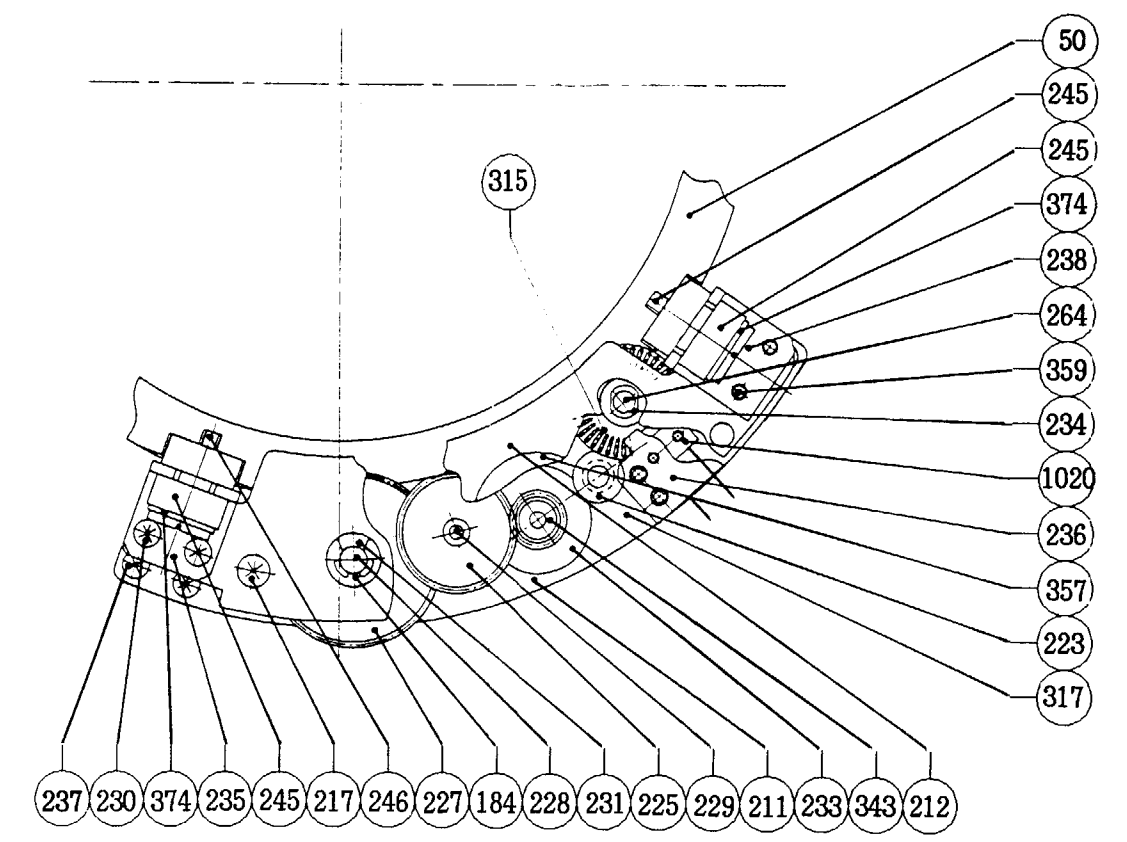

C-C (2:1)

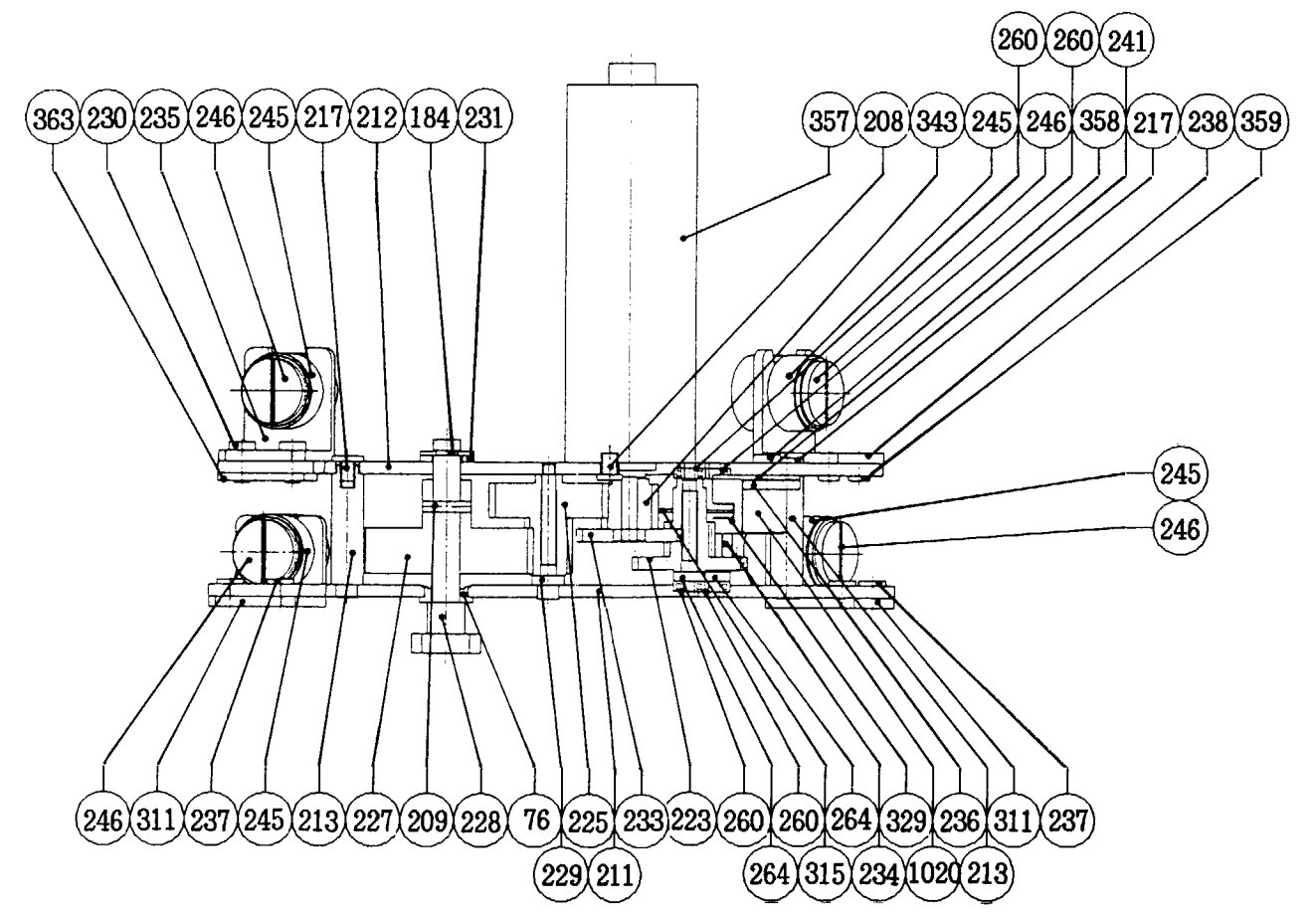

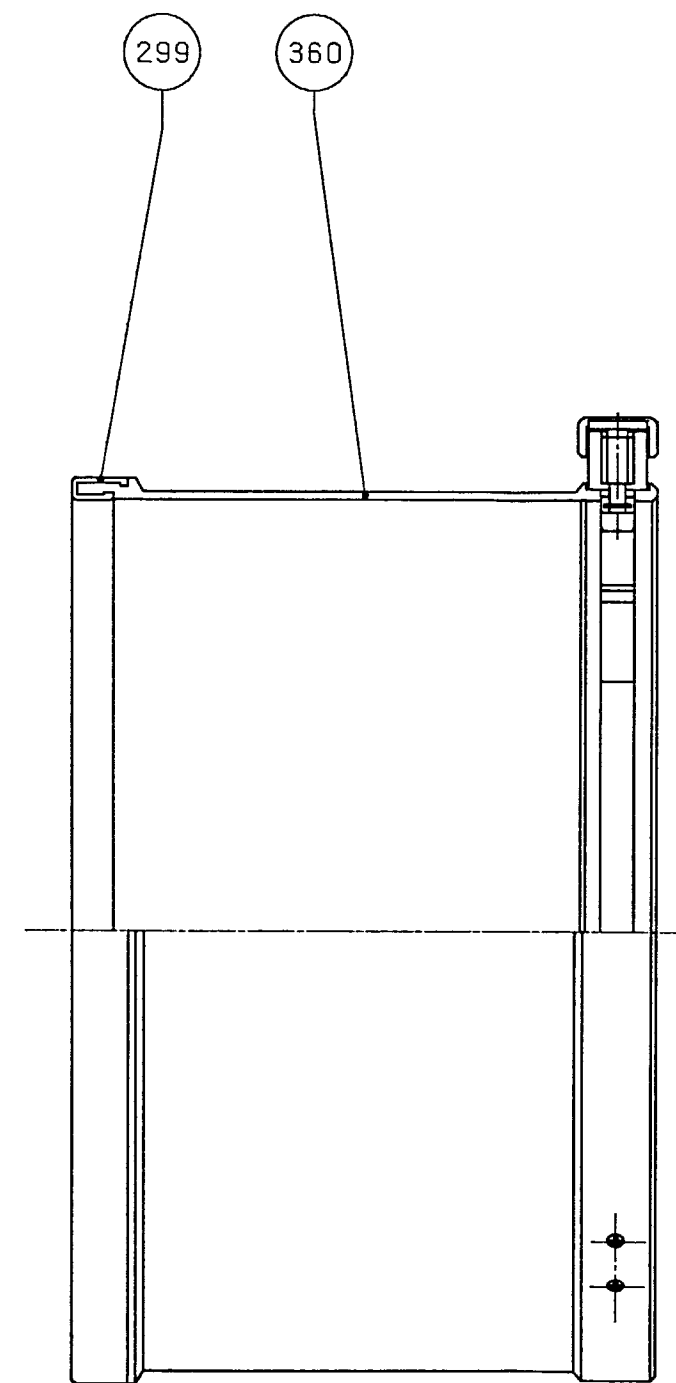
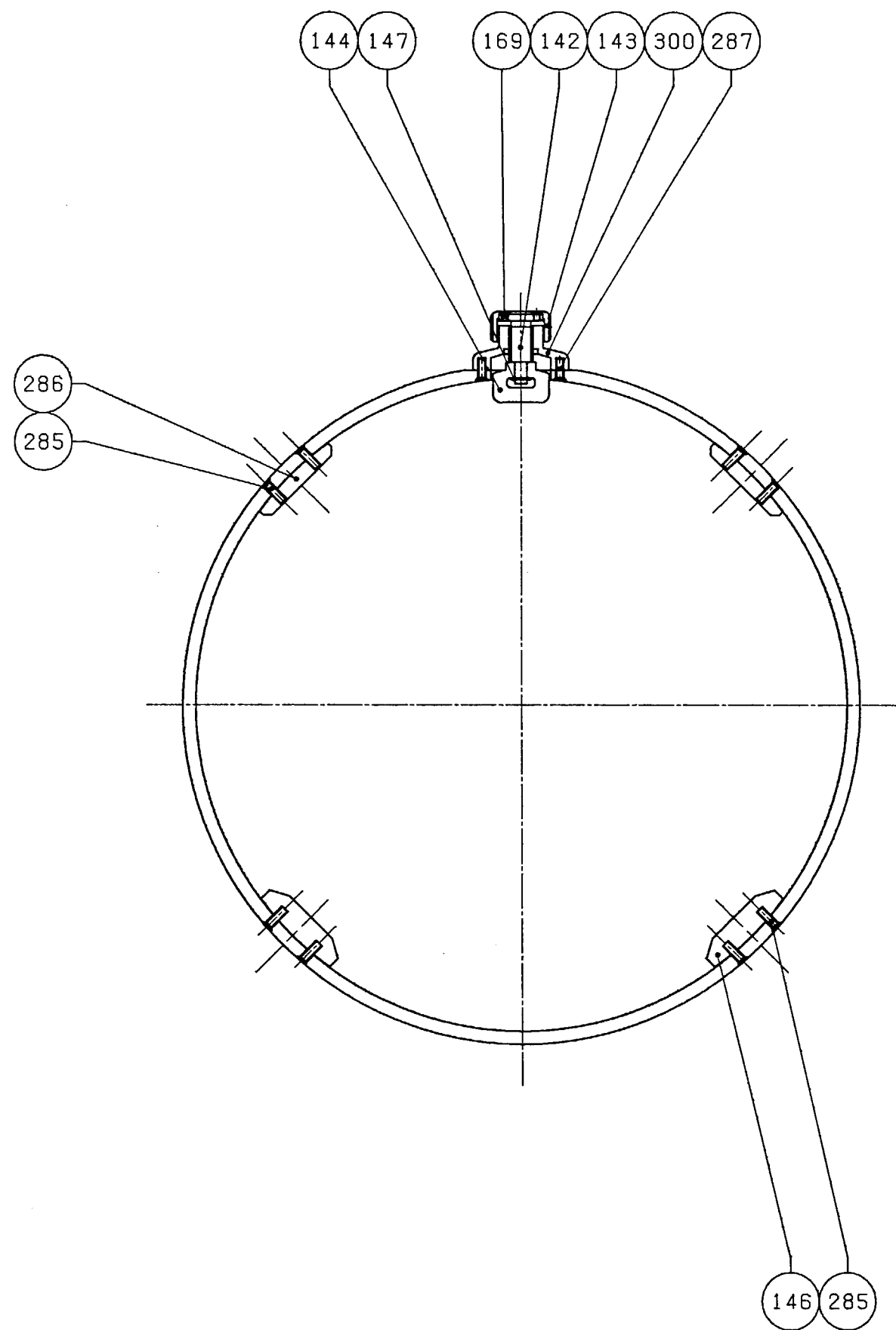

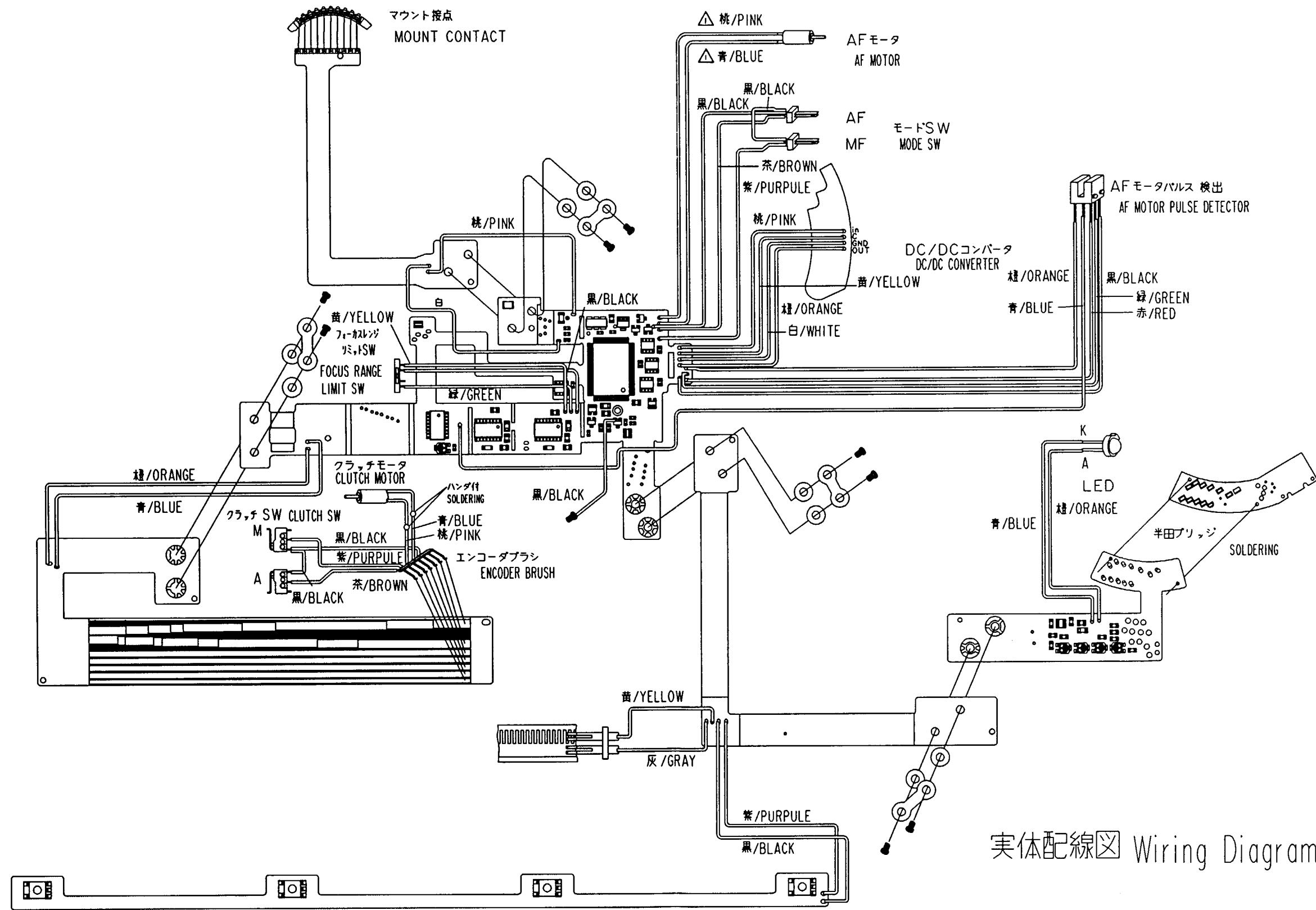

実体配線図 Wiring Diagram



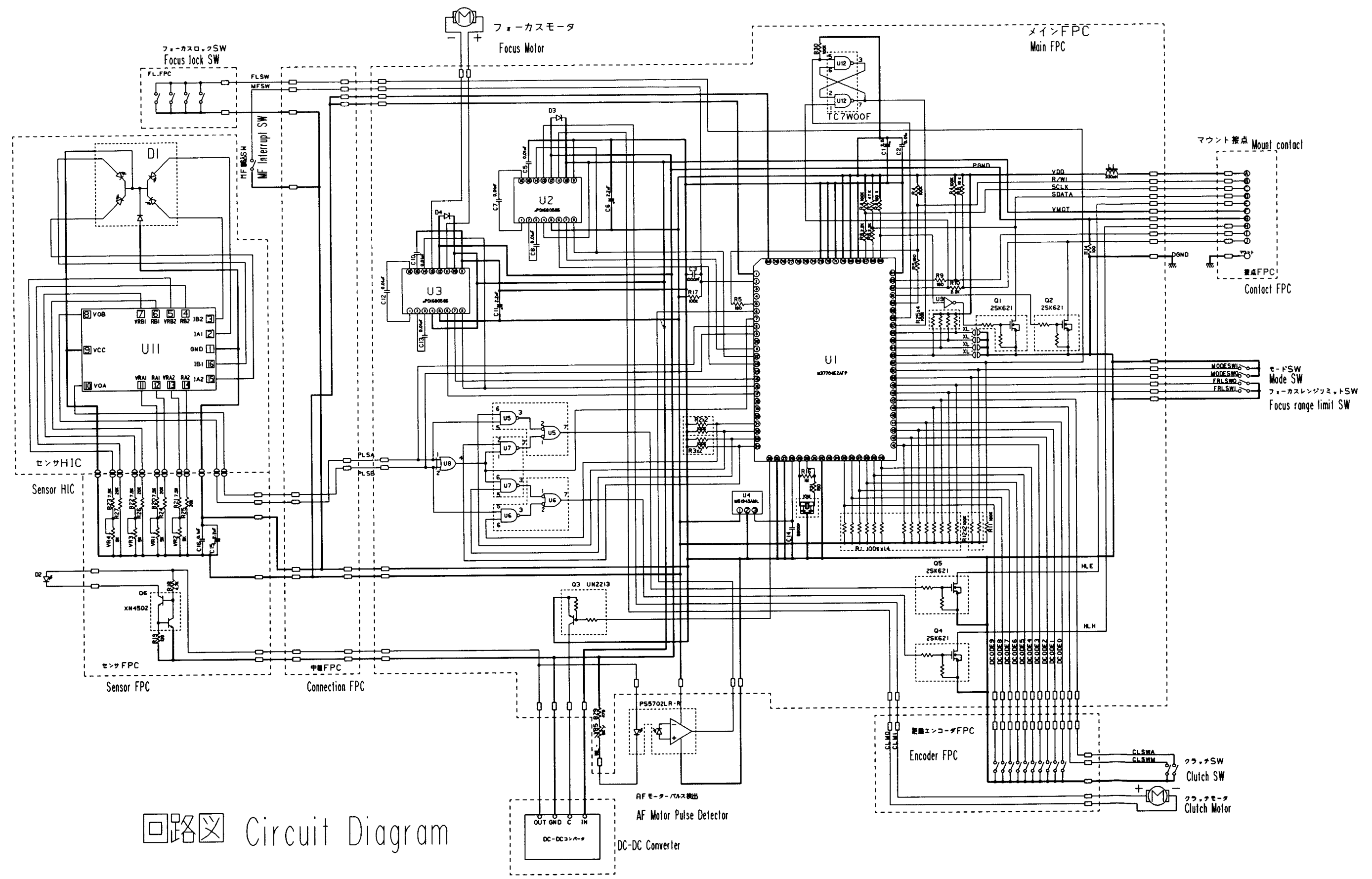

回路図 Circuit Diagram

MAIN FPC

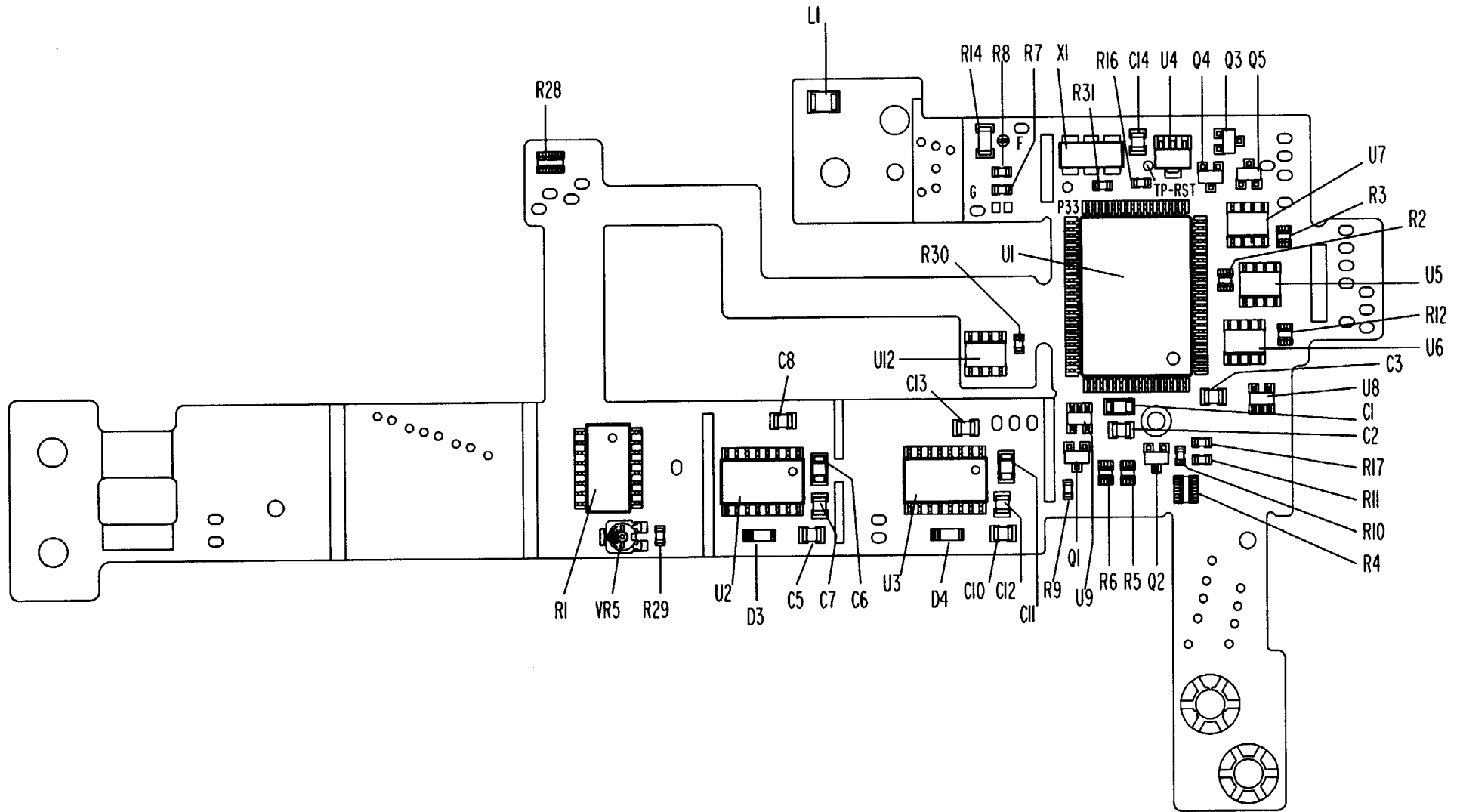

LED FPC

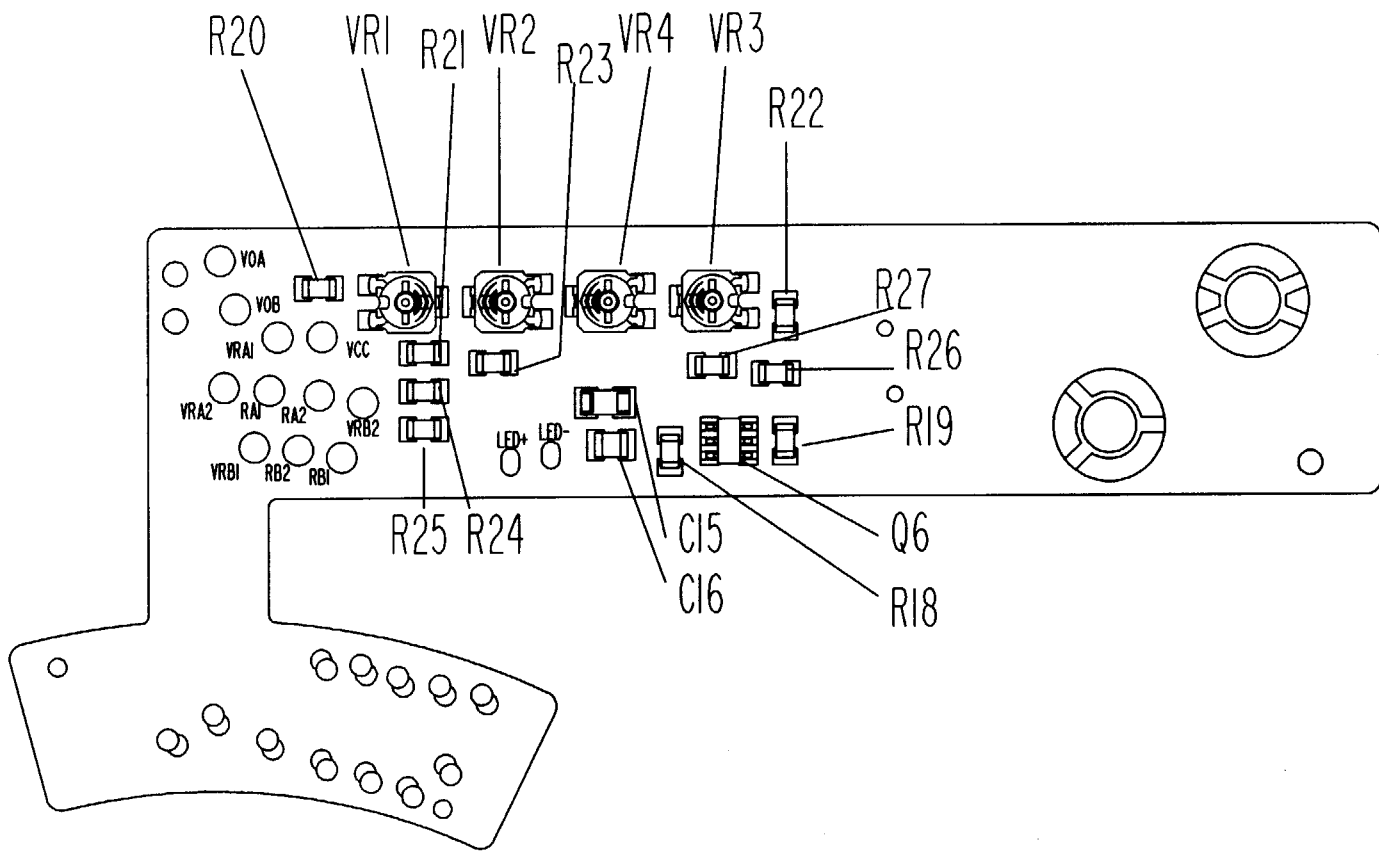

展開図中の部品位置を確認する手順
HOW TO FIND THE PART WITH PART NUMBER
IN THE DRAWING

部品表 Parts List

部品番号 Part No.	補助番号 Ckt No.	名称 Name	1台分 個数 Qty Per Unit	部組品番号 Assembly	参照 図番 Fig. No	販売区分 Class. of Salabil- ity	備考 Remarks	要求単位 Order Unit Qty
*1K240-516	573	シュー座板バネ Accessory shoe spring	1	1B990-712-2	9 A1	○△	F-401S F-601	5
*1K240-713-1	527	ロックバネB Lock spring B	1	1B990-712-2	10 A2	○△		5

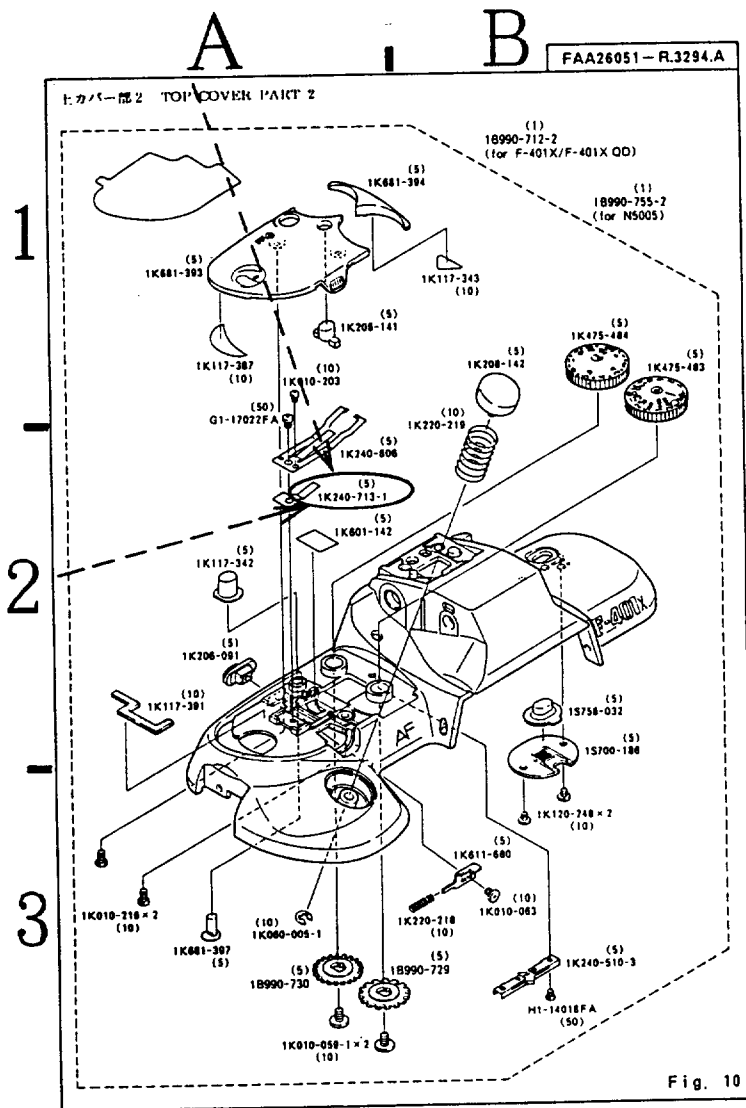

① 部品表の参照図番欄のコードを見る。

Please refer to the letters written in the Fig. No. Column.

② 9, 10等の数字は図面番号を示す。

The numbers 9 and 10 mean the Fig. number.

③ A1, A2等のアルファベットと数字の組み合わせは、図面中の部品の位置を示す。

例 A, B... は横方向の位置を示す。
1, 2... は縦方向の位置を示す。

※ よって1K240-713-1 はAと2が示す範囲内にある。

The combinations of alphabets and numbers, A1 and A2, point out the place of relevant parts in the drawing.

Example)

Alphabets like A and B point out the places along the horizontal direction.

Numbers like 1 and 2 point out the places along the vertical direction.

※It means that the part No. 1K240-713-1 is existing in the area where A and 2 are crossing.

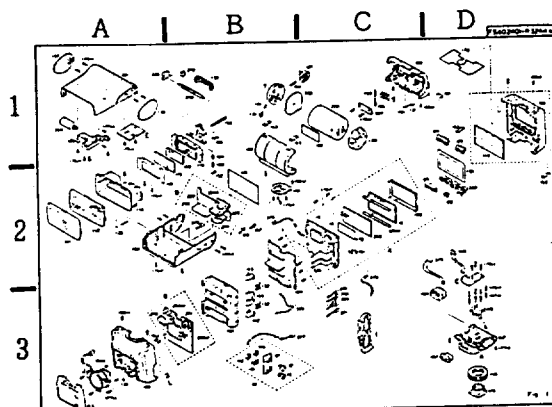

④ 例外 -- ビス, ワッシャー等は Fig No. のみ記載する。

As for screws and washers and the like, no code number showing existing place is discribed in the Fig. No. Column, but only the relevant drawing number (Fig. No.) is stated.

展開図 Exploded Drawings

JAA52051-R.3336. B

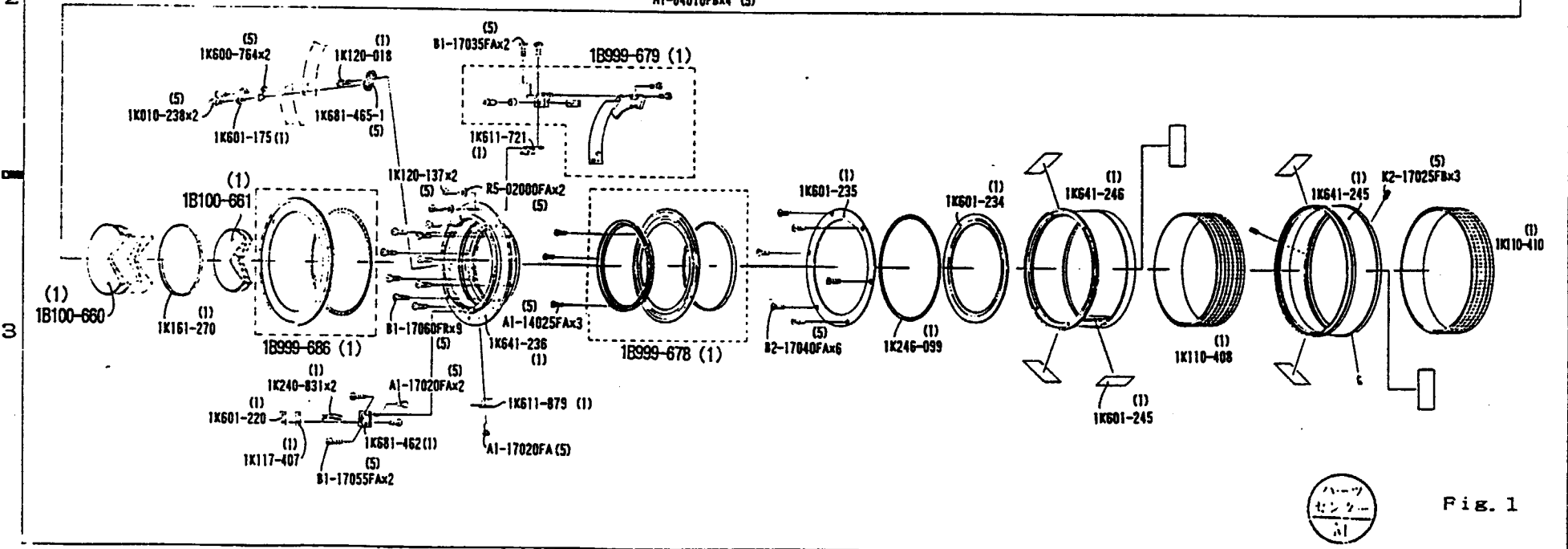
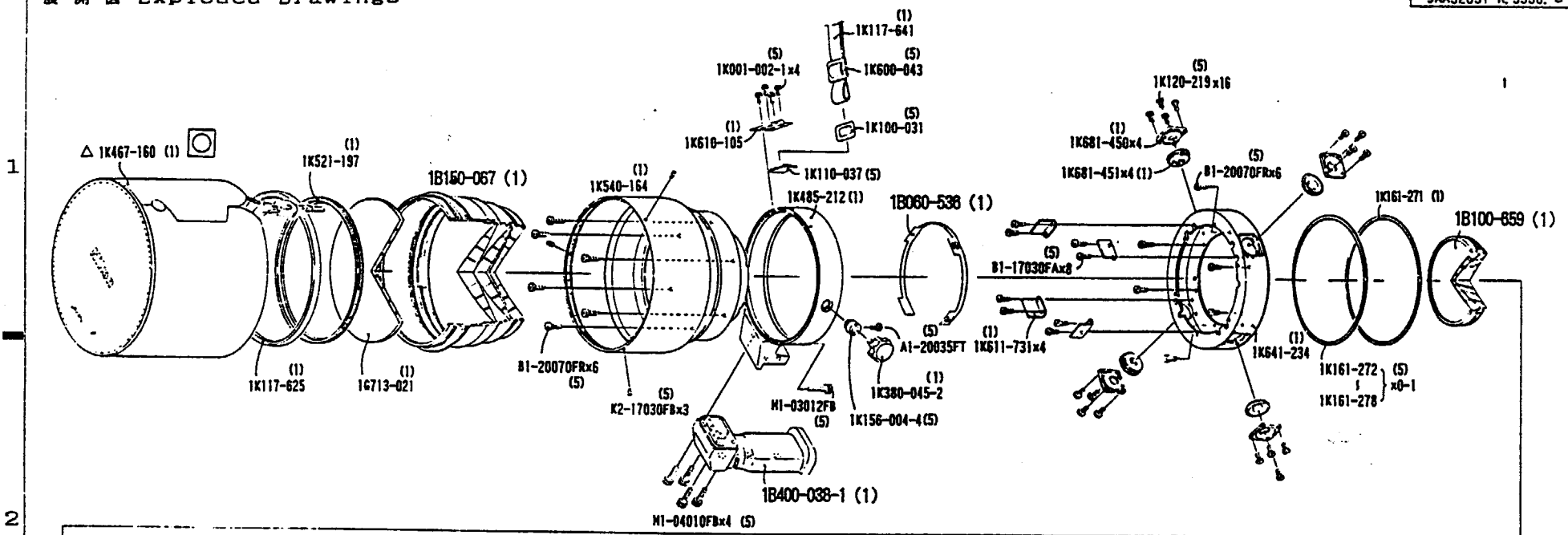

Fig. 1

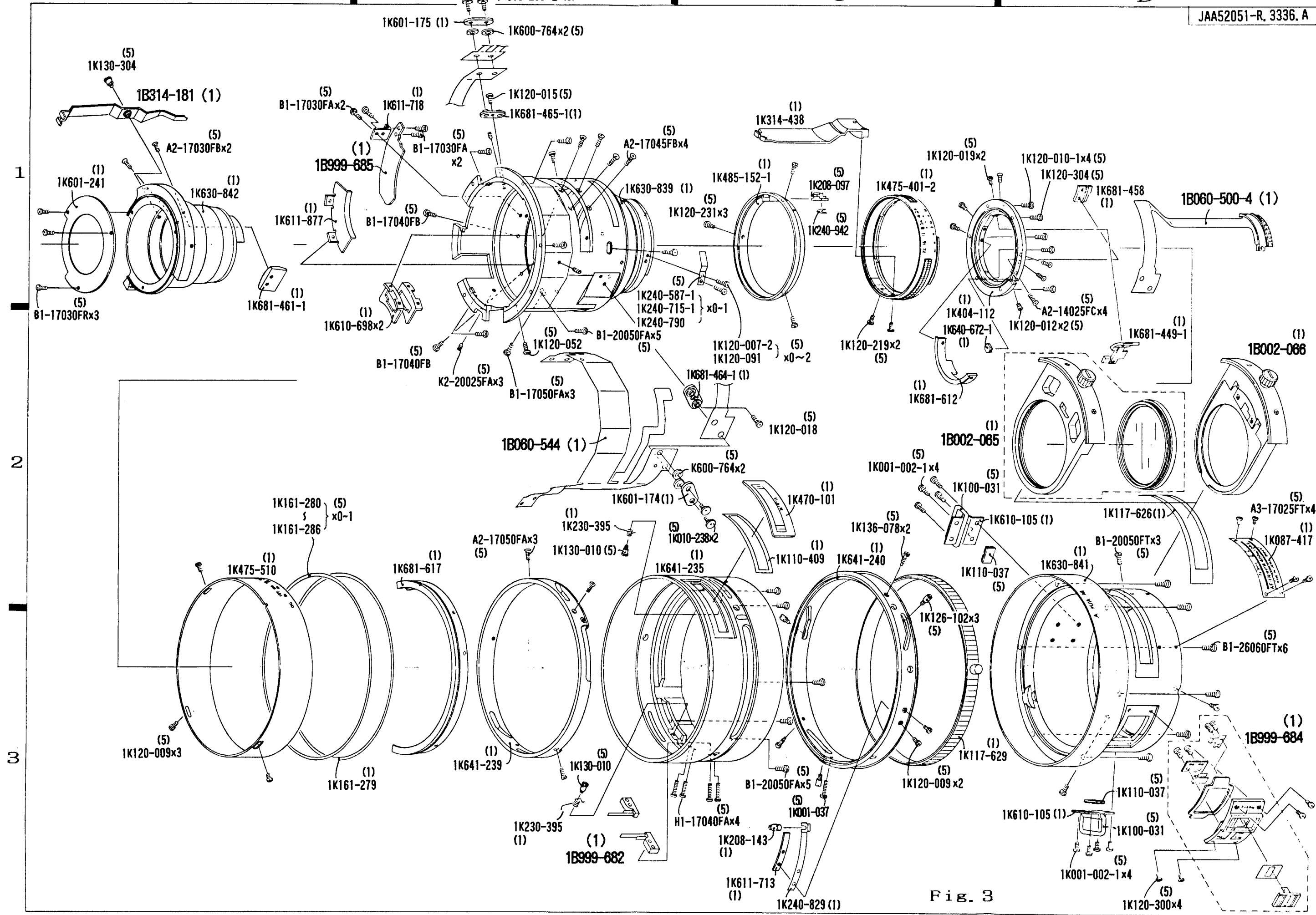

Fig. 3

〔2〕 部品表 Parts List

AF-I 400/2.8D

JAA52051-R.3336.A

部品番号 Part No.	補助番号 Ckt No.	名称 Name	1台分 個数 Pcs. Per Unit	部組品番号 Assembly	参照 図番 Fig. No.	販売区分 Term of Delivery	備考 Remarks	要求単位 Qty per order
*1K001-002-1 (1K001-002)	139	Screw	12		1-B1 3-C2 3-D3	○		5
1K001-037	195	Screw	1		3 C3	○		5
*1K010-238	289	Screw	8		1-A2 2-D3 3-B1. C2	○		5
*1K050-282	374	Washer	4		2 C3	○		1
1K087-417	269	銘板 Name plate	1		3 D2	○	No. 200001 ~	1
*1K100-031	135	吊り環 Eyelet	3		1-C1 3-C2 3-D3	○		5
*1K110-037	123	ゴム板 Rubber plate	3		1-C1 3-C2 3-D3	○		5
1K110-408	37	ゴムリング Rubber ring	1		1 D3	○		1
1K110-409	106	両面テープ Tape	1		3 C2	○		1
1K110-410	176	ゴムリング Rubber ring	1		1 D3	○		1
1K117-228	327	コード整理用テープ 5 X 1 0 Tape	1			×	TA-0006S	1 set (20pcs)
*1K117-407	203	マイラーシート Sheet	1		1 A3	○		1
1K117-625	54	保護ゴム Cover ring	1		1 A1	○		1
1K117-626	59	両面テープ Tape	1		3 D2	○		1
1K117-629	310	ゴムリング Rubber ring	1		3 C3	○		1

部品表 Parts List

AF-I 400/2.8D

JAA52051-R.3336.A

部品番号 Part No.	補助番号 Ckt No.	名称 Name	1台分 個数 Pcs. Per Unit	部組品番号 Assembly	参照 図番 Fig. No.	販売区分 Term of Delivery	備考 Remarks	要求単位 Q'ty per order
1K117-630	373	ガイド環 t=1.5 Guide ring	0-2		2 B1	○		5
1K117-631		ガイド環 t=1.45 Guide ring	0-2		2 B1	○		5
1K117-632		ガイド環 t=1.4 Guide ring	0-2		2 B1	○		5
1K117-641	130	Belt	1		1 C1	○		1
*1K120-007-2	125	Screw	0-2		3 C1	○		5
*1K120-009	255	Screw	5	1B999-683	2-B1 3-A3 3-C3	○△		5
*1K120-010-1 (1K120-010)	127	Screw	4		3 D1	○		5
*1K120-012	129	Screw	1		3 D1	○		5
*1K120-015	237	Screw	8	1B999-680 1B999-683	3 B1	○△		5
*1K120-018	296	Screw	3		1-A2 1-D2 3-C2	○		5
*1K120-019	158	Screw	4		3 C1	○		5
*1K120-036-1 (1K120-036)	120	Screw	2		2 D3	○		5
*1K120-052	305	Screw	1		3 B2	○		5
*1K120-073	126	Screw	3		2 C3	○		5
*1K120-091	125	Screw	0-2		3 C1	○		5

部品表 Parts List

AF-I 400/2.8D

JAA52051-R.3336.A

部品番号 Part No.	補助番号 Ckt No.	名称 Name	1台分 個数 Pcs. Per Unit	部組品番号 Assembly	参照 図番 Fig. No.	販売区分 Term of Delivery	備考 Remarks	要求単位 Q'ty per order
*1K120-137	224	Screw	2		1 B3	○		5
*1K120-219	95	Screw	18		1-C1 3-C2	○		5
*1K120-231	98	Screw	5		3 C1	○		5
*1K120-300	298	Screw	4		3 D3	○		5
*1K120-304	226	Screw	1		3 D1	○		5
1K120-400	216	Screw	4		2 B1	○		5
*1K126-102	77	Screw	3		3 C3	○		5
*1K130-010	248	Screw	2		3-B2 3-B3	○		5
*1K130-304	124	Screw	1		3 A1	○		5
*1K130-496	183	Screw	0-2		2 B1	○		5
△ *1K130-497	246	Screw	4		2 C3	○	RP-9583	5
△ *1K130-565								
*1K130-504	183	Screw	0-2		2 B1	○		5
1K130-526	372	Screw	2		2 B1	○		5
*1K133-007	99	Screw	1		2 D3	○		5
1K136-078	199	Screw	2		3 C2	○		5
*1K156-004-4	309	Nut	2		1 C1	○		5

Change page (差し替え) △×2

OCT. 3. 1995



部品表 Parts List

AF-I 400/2.8D

JAA52051-R.3336.A

部品番号 Part No.	補助番号 Ckt No.	名称 Name	1台分 個数 Pcs. Per Unit	部組品番号 Assembly	参照 図番 Fig. No.	販売区分 Term of Delivery	備考 Remarks	要求単位 Qty per order
1K161-270	122	Washer t=2.5	1		1 A3	○		1
1K161-271	179	Washer t=0.3	1		1 D1	○		1
1K161-272	180	Washer t=0.2	0		1 D1	○		1
1K161-273		Washer t=0.1	0		1 D1	○		1
1K161-274		Washer t=0.05	0		1 D1	○		1
1K161-275		Washer t=0.06	0		1 D1	○		1
1K161-276		Washer t=0.07	0		1 D1	○		1
1K161-277		Washer t=0.08	0		1 D1	○		1
1K161-278		Washer t=0.09	0		1 D1	○		1
1K161-279	221	Washer t=0.3	1		3 A3	○		1
1K161-280	222	Washer t=0.2	0		3 A3	○		1
1K161-281		Washer t=0.1	0		3 A3	○		1
1K161-282		Washer t=0.05	0		3 A3	○		1
1K161-283		Washer t=0.06	0		3 A3	○		1
1K161-284		Washer t=0.07	0		3 A3	○		1
1K161-285		Washer t=0.08	0		3 A3	○		1
1K161-286		Washer t=0.09	0		3 A3	○		1

部品表 Parts List

AF-I 400/2.8D

JAA52051-R.3336.A

部品番号 Part No.	補助番号 Ckt No.	名称 Name	1台分 個数 Pcs. Per Unit	部組品番号 Assembly	参照 図番 Fig. No.	販売区分 Term of Delivery	備考 Remarks	要求単位 Q'ty per order
*1K208-097	172	ロック釦 Lock button	1		3 C1	○		5
*1K208-143	85	マクロ釦 Macro button	1		3 C3	○		1
*1K220-355	187	Spring	1		2 B1	○		1
1K220-376	338	Spring	1		2 B1	○		1
*1K225-116	96	Spring	1		2 D3	○		1
1K225-242	188	Spring	1		2 B1	○		1
1K230-395	247	Spring	2		3 B2	○		1
*1K240-942 (1K240-563)	173	EEロックバネ EE lock spring	1		3 C1	○		5
*1K240-587-1	36	板バネ t=0.2 Leaf spring	0		3 C1	○		1
*1K240-715-1		板バネ t=0.18 Leaf spring	0		3 C1	○		1
*1K240-790		板バネ t=0.15 Leaf spring	0		3 C1	○		1
*1K240-829	87	曲げ板 Bent plate	1		3 C3	○		1
*1K240-831	201	ブラシ Brush	2		1 A3	○		1
1K246-099	119	波形ワッシャー Washer	1		1 C3	○		1
1K246-100	340	波形ワッシャー Washer	1		2 C2	○		1
1K314-438	62	連動レバー Lever	1		3 C1	○		1

部品表 Parts List

AF-I 400/2.8D

JAA52051-R.3336.B

部品番号 Part No.	補助番号 Ckt No.	名称 Name	1台分 個数 Pcs. Per Unit	部組品番号 Assembly	参照 図番 Fig. No.	販売区分 Term of Delivery	備考 Remarks	要求単位 Q'ty per order
*1K371-706	102	軸 Axle	2		2 B1	○		1
1K380-045-2	70	クランプネジ	1		1 C2	○		1
*1K404-112	30	バヨネット Bayonet mount	1		3 C1	○		1
△ 1K467-160	366	キャップ Cap	1		1 A1	○	RP-9603	1
1K470-101	57	アクリル窓 Acryle plate	1		3 C2	○		1
*1K475-401-2 (1K475-401)	28	絞り環 Diaphragm ring	1		3 C1	○		1
1K475-510	26	距離環 Focus ring	1		3 A3	○		1
*1K485-152-1 (1K485-152)	105	指標環 Index ring	1		3 C1	○		1
1K485-212	69	三脚座リング Tripod attaching ring	1		1 C1	○		1
1K521-197	47	G1 押さえ環 G1 retaining ring	1		1 A1	○		1
1K521-202	339	押さえ環 Retaining ring	1		2 D2	○		1
1K530-072	24	リード溝環 Inner tube	1		2 B2	○		1
1K540-164	38	鏡筒 Lens barrel	1		1 B1	○		1
1K572-164	33	羽根基板 Blade mount plate	1		2 C3	○		1
*1K600-043	131	Plate	2		1 C1	○		5
*1K600-722	79	Plate	1		2 D3	○		5
*1K600-764	290	圧接ゴム Rubber	8		1-A2. D2 3-B1. C2	○		5



部品表 Parts List

AF-I 400/2.8D

JAA52051-R. 3336. A

部品番号 Part No.	補助番号 Ckt No.	名称 Name	1台分 個数 Pcs. Per Unit	部組品番号 Assembly	参照 図番 Fig. No.	販売区分 Term of Delivery	備考 Remarks	要求単位 Q'ty per order
*1K601-174	267	Plate	2		2-D3 3-C2	○		1
*1K601-175	268	Plate	2		1-A2 3-B1	○		1
*1K601-220	204	Plate	1		1 A3	○		1
1K601-234	111	Plate	1		1 C3	○		1
1K601-235	118	押さえ板 Retaining plate	1		1 C3	○		1
1K601-241	337	Plate	1		3 A1	○		1
1K601-245	270	Plate	1		1 C3	○		1
*1K610-105	75	曲げ板 Bent plate	3		1-B1 3-C2 3-D3	○		1
*1K610-698	83	曲げ板 Bent plate	2		3 B1	○		1
*1K611-713	88	曲げ板 Bent plate	1		3 C3	○		1
*1K611-718	171	曲げ板 Bent plate	1		3 B1	○		1
*1K611-721	207	曲げ板 Bent plate	1		1 B2	○		1
*1K611-731	51	曲げ板 Bent plate	4		1 C1	○		1
1K611-872	107	Lever	1		2 B1	○		1
1K611-873	108	Lever	1		2 B1	○		1

1K641-241	78	丸環 Ring	1		2 C3	○		1
1K641-243	84	丸環 Ring	1		2 A3	○		1
1K641-244	117	後部固定環 Rear fixed ring	1		2 B3	○		1
1K641-245	167	丸筒 Tube	1		1 D3	○		1

部品表 Parts List

AF-I 400/2.8D

JAA52051-R. 3336. A

部品番号 Part No.	補助番号 Ckt No.	名称 Name	1台分 個数 Pcs. Per Unit	部組品番号 Assembly	参照 図番 Fig. No.	販売区分 Term of Delivery	備考 Remarks	要求単位 Q'ty per order
1K641-246	168	丸筒 Tube	1		1 C3	○		1
1K641-248	344	丸環 Ring	1		2 A3	○		1
1K641-254	341	丸環 Ring	1		2 C1	○		1
*1K681-449-1 (1K681-449)	39	丸環 Ring	1		3 D2	○		1
*1K681-450	63	Block	4		1 C1	○		1
*1K681-451	64	Block	4		1 C1	○		1
*1K681-458	161	曲げ板 Bent plate	1		3 D1	○		1
*1K681-461-1 (1K681-461)	200	Block	1		3 A1	○		1
*1K681-462	205	Block	1		1 A3	○		1
*1K681-464-1	262	Block	2		2-D2 3-C2	○		1
*1K681-465-1	263	Block	2		1-A2 3-B1	○		1
1K681-610	150	フォーカス回転制限 Focus rimit plate	1		2 D2	○		1
1K681-612	159	曲げ板 Bent plate	1		3 C2	○		1
1K681-613	190	曲げ板 Bent plate	1		2 A1	○		1
1K681-614	191	曲げ板 Bent plate	2		2 B2	○		1

〔2〕 部品表 Parts List

AF-I 400/2.8D

JAA52051-R. 3336. A

部品番号 Part No.	補助番号 Ckt No.	名称 Name	1台分 個数 Pcs. Per Unit	部組品番号 Assembly	参照 図番 Fig. No.	販売区分 Term of Delivery	備考 Remarks	要求単位 Q'ty per order
1G713-021	G1	G1レンズ G1 lens element	1		1 A1	○		1
A1-14025FA	148	Screw	3		1 B3	○△		5
A1-17020FA	208	Screw	4		1-A3 1-B2	○		5
A1-20035FT	116	Screw	1		1 C1	○		5
A2-14025FC	261	Screw	2		3 D1	○		5
A2-17025FA	145	Screw	3		2 C3	○		5
A2-17030FB	218	Screw	2		3 A1	○		5
A2-17045FB	100	Screw	4		3 B1	○		5
A2-17050FA	370	Screw	3		3 B2	○		5
A2-20028FA	295	Screw	2		2 D2	○		5
A3-17025FT	297	Screw	4		3 D2	○		5
B1-14030FA	230	Screw	7	1B999-680 1B999-679	2 A3	○△		5
B1-17030FA	251	Screw	19	1B999-683	1-C1 2-A1. B2 3-B1. B2	○△		5
B1-17030FR	336	Screw	3		3 A1	○		5
B1-17035FA	288	Screw	8		1-B2 2-A1 2-B1	○		5
B1-17040FB	347	Screw	2		3-B1 3-B2	○		5

部品表 Parts List

AF-I 400/2.8D



JAA52051-R. 3336. A

部品番号 Part No.	補助番号 Ckt No.	名称 Name	1台分 個数 Pcs. Per Unit	部組品番号 Assembly	参照 図番 Fig. No.	販売区分 Term of Delivery	備考 Remarks	要求単位 Q'ty per order
B1-17040FA	364	Screw	6		2-A3 2-B2	○		5
B1-17050FA	277	Screw	3		3 B2	○		5
B1-17055FA	202	Screw	2		1 A3	○		5
B1-17060FR	253	Screw	9		1 B3	○		5
B1-20050FA	257	Screw	16		2-B3 3-B2 3-C3	○		5
B1-20050FT	345	Screw	3		3 D2	○		5
B1-20070FR	256	Screw	12		1-B1 1-D1	○		5
B1-26060FT	259	Screw	6		3 D3	○		5
B2-17030FA	219	Screw	1		2 A1	○		5
B2-17040FA	278	Screw	6		1 C3	○		5
B2-20050FA	293	Screw	2		2 B3	○		5
H1-17035FA	368	Screw	2		2 A1	○		5
H1-17040FA	215	Screw	4		3 C3	○		5
K2-17025FB	294	Screw	3		1 D3	○		5
K2-17030FB	252	Screw	3		1 D2	○		5
K2-20025FA	220	Screw	3		3 B2	○		5

部組品表 Assembly List

AF-I 400/2.8D

JAA52051-R. 3336. A

部組番号 Part No.	補助番号 Ckt No.	名称 Name	1台分 個数 Pcs. Per Unit	構成部品番号 Constituent Parts	参照 図番 Fig. No.	備考 Remarks	要求単位 Q'ty per order
*1B002-041	B34	基板カバー Plate cover	1	1K116-561-1 1K110-398	2 B3		1
1B002-064	B4	リード溝環 Inner tube unit	1	1K641-237 1K630-840 1K260-645	2 D1		1
1B002-065	B9	フィルターホルダー Filter holder	1	1K681-608 1B002-067 1K680-024 1K220-021-1 P3-10050SX 1K480-001-1 1K681-616 1K001-003-1x2	3 D2	商品扱い 	
1B002-066	B10	ゼラチンフィルターホルダー Gelatin filter holder	1	1K681-609 A2-20040FTx2 1K625-059 1K233-008-2 1K480-001-1 1B002-067 1K220-021-1 P3-10050SX 1K680-024 1K117-627 1K661-874 1K681-616 1K001-003-1x2	3 D2	商品扱い 	
1B002-068	B12	レバー組 Lever unit	1	1K641-242 1B310-046 1K371-135	2 D3		1
*1B060-500-4	B22	接点FPC組 Connecting FPC unit	1	1S705-228-2 1K681-572 1K611-788-3 1K240-469-1x10 1K117-525 1K681-539 1K117-485	3 D1		1
1B060-534	B25	距離エンコーダFPC組 FPC unit	1	1S705-260 1K117-463	2 B3		1
1B060-535	B26	中継FPC組 Relay FPC unit	1	1S705-261 1K117-079x3 1K117-413x2	2 C1		1
1B060-536	B27	フォーカスロックFPC組 Focus lock FPC unit	1	1S020-087 1K117-079	1 C1		1

部品表 Parts List

AF-I 400/2.8D

JAA52051-R. 3336. A

部品番号 Part No.	補助番号 Ckt No.	名称 Name	1台分 個数 Pcs. Per Unit	部組品番号 Assembly	参照 図番 Fig. No.	販売区分 Term of Delivery	備考 Remarks	要求単位 Q'ty per order
M1-03012FB	280	Bolt	1		1 C2	○		5
M1-04010FB	352	Bolt	4		1 B2	○		5
R5-02000FA	197	Washer	2		1 B3	○		5
S1-02000FA	184	E-ring	4	1B999-680 1B999-683	2 B1	○△		5

部組品表 Assembly List

AF-I 400/2.8D

JAA52051-R. 3336. A

部組番号 Part No.	補助番号 Ckt No.	名称 Name	1台分 個数 Pcs. Per Unit	構成部品番号 Constituent Parts	参照 図番 Fig. No.	備考 Remarks	要求単位 Q'ty per order
1B060-544	B23	メインFPC組 Main FPC unit	1	1S020-103 1K117-525x5 1K117-526x2 1K116-368x2	3 B2		1
1B100-659	B1	G5. G6レンズ室組 G5.G6 lens housing unit	1	1G254-094 1G154-121 1K500-867	1 D1		1
1B100-660	B2	G7. G8. G9レンズ室組 G7.G8.G9 lens housing unit	1	1G215-027 1G154-122 1G213-032 1K500-865	1 A3		1
1B100-661	B3	G10. G11レンズ室組 G10.G11 lens housing unit	1	1G114-117 1G257-069 1K500-866	1 A3		1
1B150-067	B6	G2. G3. G4レンズ室組 G2.G3.G4 lens housing unit	1	1G116-040 1G117-049 1G217-020 1K510-406 1K521-198 1K521-195 1K521-196 1S811-699	1 B1	*工場送り	1
1B300-027	B13	カム組 Cam unit	1	1K300-094 1K370-615	2 D3		1
1B314-181	B16	シーソーレバー組 Lever fixing	1	1K314-437 1K340-133	3 A1		1
*1B400-038-1 (1B400-038)	B7	三脚座 Tripod attaching	1	1K400-222-1 U2-08315SXx3	1 B2		1
1B570-129	B17	羽根組 Blade unit	9	1K570-129 1K370-607-1x2	2 C3		10
*1B574-065	B33	羽根基板組 Brade mounting plate unit	1	1K574-125 1K600-723 1K042-001x2 1K370-845	2 D3		1

部組品表 Assembly List

AF-I 400/2.8D

JAA52051-R. 3336. A

部組番号 Part No.	補助番号 Ckt No.	名称 Name	1台分 個数 Pcs. Per Unit	構成部品番号 Constituent Parts	参照 図番 Fig. No.	備考 Remarks	要求単位 Q'ty per order
*1B999-534		ガイド環 φ5 +0.04 Guide ring +0.03	3	1K130-238-1 1K117-563	2 D1		5
*1B999-535		ガイド環 φ5 +0.03 Guide ring +0.02	3	1K130-238-1 1K117-564	2 D1		5
*1B999-536		ガイド環 φ5 +0.02 Guide ring +0.01	3	1K130-238-1 1K117-565	2 D1		5
*1B999-537		ガイド環 φ5 +0.01 Guide ring 0	3	1K130-238-1 1K117-566	2 D1		5
*1B999-538		ガイド環 φ5 0 Guide ring -0.01	3	1K130-238-1 1K117-567	2 D1		5
1B999-678		ガラスエンコーダ組 Lens barrel unit	1	1G766-002 1K521-199 1K641-247	1 B3		1
1B999-679	B97	LED部組 LED unit	1	1G767-002 1K681-463 B1-14030FAx2 1K117-437 1K117-525x2 1K117-527 1S260-058 1S811-511 1S811-510 1B060-502-2 1S007-232	1 B2		1
1B999-680	B81	AFギア組 AF gear unit	1	S1-02000FA 1K120-075x2 1K277-157 1K277-156 B1-14030FAx2 R1-02600FA 1K260-649 1K611-750 1K601-239 1K120-015x4 1K611-723 1K601-296 1K117-410x4 1K070-036x4 1K371-784x2 1K611-738x2 1K641-181 1K611-883 A1-14025FAx2 A1-14020FAx2 1K601-187 1S258-016-1 1S811-721 1S811-510 1S811-723 1S811-725 1S811-726 1B260-102 1B060-538	2 C2		1

部組品表 Assembly List

AF-I 400/2.8D

JAA52051-R.3336.A

部組番号 Part No.	補助番号 Ckt No.	名称 Name	1台分 個数 Pcs. Per Unit	構成部品番号 Constituent Parts	参照番 図番 Fig. No.	備考 Remarks	要求単位 Q'ty per order
1B999-681	B69	ブラシ組 Brush unit	1	1S811-523 1S811-524 1S811-525 1S811-655 1S811-656 1B240-102	2 A1		1
1B999-682	B83	スイッチ組 Switch unit	1	1S811-529 1S811-530 1S811-531 1S811-540 1B610-117x2	3 B3		1
1B999-683	B61	AFギア組 AF gear unit	1	1K277-134 1K371-707 1K611-875 1K601-236 1K220-354 S1-02000FAx2 1K260-612 1K260-613 1K641-160x8 1B060-498 1K371-710 1K120-015x3 1K060-058x2 B1-17030FAx2 1K681-468 1K120-009 A2-14020FA 1B260-101 1K630-793 1K630-817 1K630-818	2 A1		1
1B999-684		フォーカスレンジSW組 Switch unit	1	1K681-611 1K117-406 1S424-033 H1-17030FAx4 1K206-104 1S700-343 1K240-832 1K681-618 1S811-526 1S811-527 1S811-528	3 D3		1
1B999-685		DC/DCコンバータ組 DC/DC converter unit	1	1S050-035 1S811-491 1S811-492 1S811-493 1S811-718	3 B1		1
1B999-686		エンコーダリング組 Barrel unit	1	1K641-238 1S700-342	1 A3		1

部組品表 Assembly List

AF-I 400/2.8D

JAA52051-R.3336.A

部組番号 Part No.	補助番号 Ckt No.	名 称 Name	1台分 個 数 Pcs. Per Unit	構成部品番号 Constituent Parts	参照 図番 Fig. No.	備 考 Remarks	要求単位 Q'ty per order
1B999-687		ガイド環 φ5 +0.03 +0.02 Guide ring	2	1K130-532 1K117-731	2 C2		5
1B999-688		ガイド環 φ5 +0.02 +0.01 Guide ring	2	1K130-532 1K117-732	2 C2		5
1B999-689		ガイド環 φ5 +0.01 0 Guide ring	2	1K130-532 1K117-733	2 C2		5
1B999-690		ガイド環 φ5 0 -0.01 Guide ring	2	1K130-532 1K117-734	2 C2		5
1B999-691		ガイド環 φ5 -0.01 -0.02 Guide ring	2	1K130-532 1K117-735	2 C2		5
1B999-692		ガイド環 φ4.5 -0.02 -0.03 Guide ring	2	1K130-328 1K116-450	2 C2		5
1B999-693		ガイド環 φ4.5 -0.01 -0.02 Guide ring	2	1K130-328 1K116-451	2 C2		5
1B999-694		ガイド環 φ4.5 0 -0.01 Guide ring	2	1K130-328 1K116-452	2 C2		5
1B999-695		ガイド環 φ4.5 +0.01 0 Guide ring	2	1K130-328 1K116-453	2 C2		5
1B999-696		ガイド環 φ5 +0.03 +0.02 Guide ring	2	1K130-529 1K437-212	2 C1		5
1B999-697		ガイド環 φ5 +0.02 +0.01 Guide ring	2	1K130-529 1K437-213	2 C1		5
1B999-698		ガイド環 φ5 +0.01 0 Guide ring	2	1K130-529 1K437-214	2 C1		5
1B999-699		ガイド環 φ5 0 -0.01 Guide ring	2	1K130-529 1K437-215	2 C1		5
1B999-700		ガイド環 φ5 -0.01 -0.02 Guide ring	2	1K130-529 1K437-216	2 C1		5
1B999-705		ガイド環 φ5 -0.02 -0.03 Guide ring	2	1K130-529 1K437-217	2 C1		5
1B999-706		ガイド環 φ5 -0.03 -0.04 Guide ring	2	1K130-529 1K437-218	2 C1		5